

(revised 4/27/01)

NUCLEAR MAGNETIC RESONANCE

Advanced Laboratory, Physics 407,
University of Wisconsin
Madison, Wisconsin 53706

Abstract

This experiment studies the Nuclear Magnetic Resonance of protons in water, the protons in the Hydrogen being essentially free. The resonance is very narrow and so this description includes some detailed instructions on how to find the resonance. The phenomenon of Nuclear Magnetic Resonance may be regarded as a precision determination of a magnetic field for the case where the resonating magnetic moment is known. The experiment also studies the effect of paramagnetic ions on the line width of the resonance and you are encouraged to both explore this phenomenon and read the literature.

Theory

The theory for magnetic dipole transitions is covered in the standard texts.

- A. Melissinos, “Experiments in Modern Physics”, Academic Press, New York, 1966, pp. 344-374.
- “R. D. Evans, “The Atomic Nucleus”, McGraw-Hill, New York, 1955, pp. 192-197.
- In addition a detailed treatment is to be found in the book by N. Bloembergen, “Nuclear Magnetic Relaxation”, W. A. Benjamin, Inc., 1961.

If nuclear magnetic moments can be subjected to electromagnetic radiation at their Larmor frequency while they are in a constant magnetic field, a nucleus in a lower magnetic energy state may absorb a quantum of energy from the radiation field and make a transition to a higher magnetic level. It turns out that this can be accomplished experimentally in several different ways and that the resonances for absorption of energy at the Larmor frequency are sharp. This phenomenon is known as Nuclear Magnetic Resonance. If the difference between the nuclear magnetic moment components is $\Delta\mu$, then the energy difference is:

$$\Delta E = \Delta\mu B.$$

The perturbations from one state to the other can be induced by electromagnetic fields of frequency f :

$$\Delta E = hf$$

Because the nuclear magnetic moments are small (when compared with electron and atomic magnetic moments) the energy difference in normal magnetic fields is about 10^{-6} of kT . Consequently all the magnetic sub levels will be populated and the perturbation will merely change the populations slightly by a few parts in a million. For this reason, the method must be capable of detecting very small energies.

Apparatus

Magnet (Alpha Scientific Labs AL7536) This has 6 inch flat poles and should be water cooled when used with currents exceeding 2 Amps. The poles are not perfectly parallel and so the most uniform magnetic field is found off the central axis.

Magnet Supply (Alpha Scientific Labs AL100 and 105R Regulator) This should be used in the current stabilized mode. Before turning the supply on, make sure that the current control is set to zero. Do not disconnect any of the connections while a magnet current exists. Why?

Marginal Oscillator This is an RF oscillator which gives an amplitude dependent on the Q of an LC circuit. The amplitude is small so that only a small energy exists in the LC circuit. The sample is in the small coil of inductance L. At the critical magnetic field corresponding to resonance the sample absorbs a very small amount of energy from the LC circuit. The RF voltage across the LC circuit will then drop slightly. A demodulating (rectifying) circuit detects the decrease in the RF level. The resulting audio signal is displayed on the oscilloscope with either a linear or sinusoidal sweep. A typical oscillator tank circuit is shown below. The actual circuit used in this experiment is functionally similar (Fig. 2).

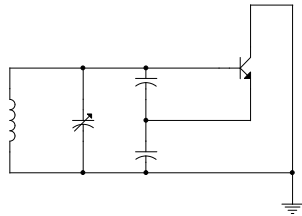

Figure 1

All the components for the circuit, including the driver for the modulation coils discussed below, are in one chassis which has three outputs with BNC connectors. The RF output is used to measure the oscillator frequency, and is connected to the frequency meter. The SWEEP output is proportional to the voltage supplied to the modulation coils, and is used to drive the X input of the scope. The AF output is the resonance signal derived from the sample and is used to drive the Y input of the scope.

The oscillator has been derived from the classical Colpits design. The diagram above is a simplified form in which all DC levels have been ignored and only the AC connections and impedances are shown. The reactive components are connected so that the voltage V_{ec} developed between the emitter and collector is fed back with opposite phase to the emitter base V_{eb} . An increase V_{eb} will cause more current to flow and will decrease V_{ec} . The resonant circuit then causes an increase in V_{eb} and so the circuit can have an overall positive feedback and oscillate. Of course, the circuit operation operation depends only on voltage differences and so any point in the circuit may be chosen to be ground.

Modulating Coils The magnetic field B is maintained by the DC current in its coils. The field is modulated at 60 Hz with two small coils mounted on each side of the NMR sample(an approximate Helmholtz Coil arrangement). This modulation field is of the order of several gauss and thus the B field is only modulated slightly(less than 1%) at a 60 Hz rate.

The AC voltage for the modulating coils is derived from a floating winding on a transformer and is arranged so that the voltage swings in the two lines are equal and opposite to reduce pickup onto the sample coil. The modulating voltage is also used to sweep the X input of the scope for the case of a sinusoidal sweep. The amplitude of the AC voltage may be varied by the “modulation” control.

Frequency Counter The frequency counter is used to measure the RF frequency of the marginal oscillator. It uses a temperature compensated crystal oscillator to establish a frequency calibration.

60 Hz Mixing The resonance occurs twice each 60 Hz cycle of the modulating coils and so the audio signals on the scope for the case of a sinusoidal sweep tend to fall on top of each other. However if a variable phase is added to the sweep voltage the traces can be seen separately. The phase control is labeled PHASE. The phase is adjusted to give a display that separates the two signals that occur during each 60 Hz period. *Oscilloscope* (Tektronix

454) The scope can be used in either the normal mode for a linear sweep or in x-y mode for the sinusoidal sweep.

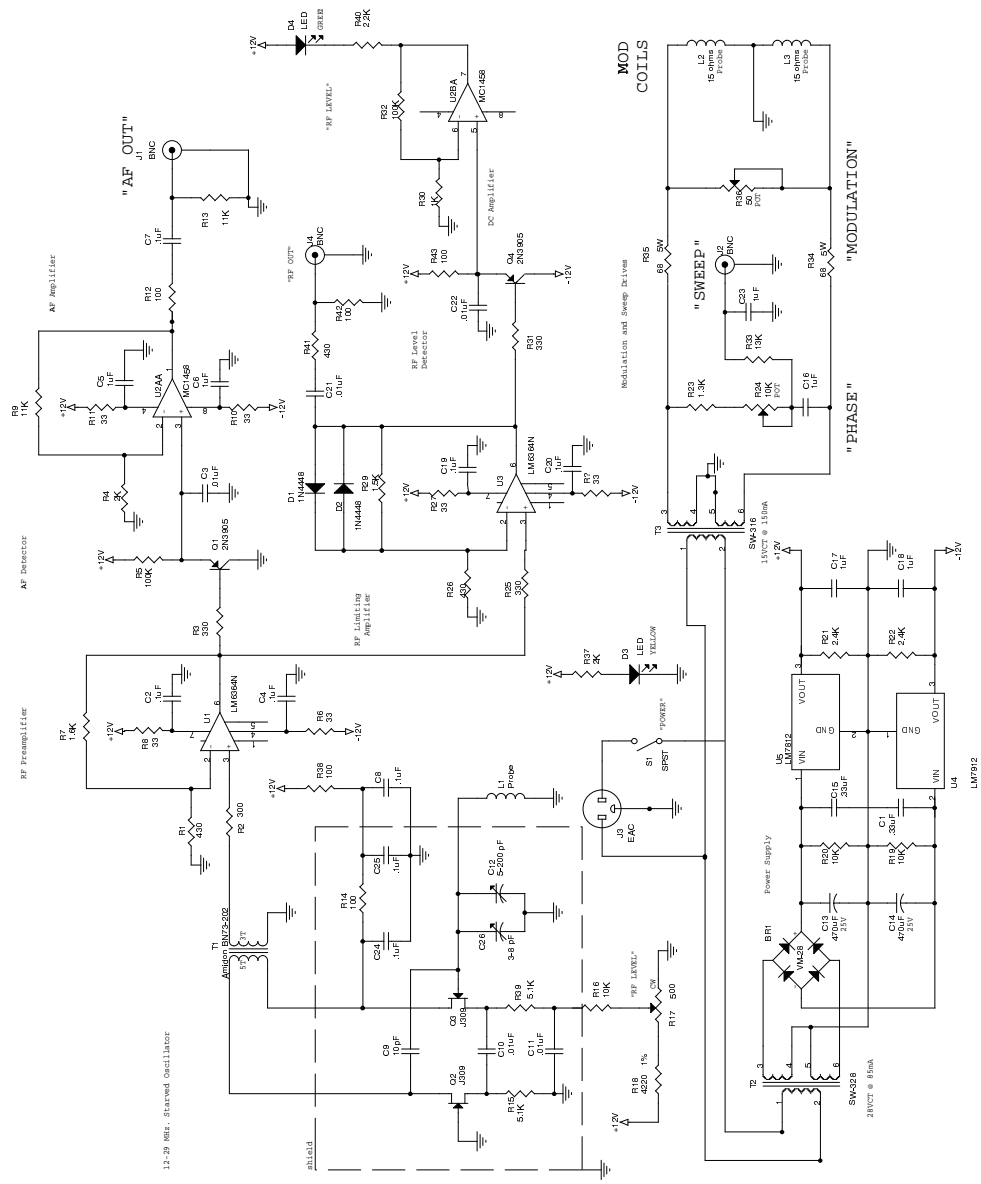

NMR OSCILLATOR and DETECTOR

Figure 2

Procedure

1. Read Melissinos, pages 358 to 374.
2. Compute the resonance frequency f for free protons in a magnetic field B from fundamental constants and the magnetic moment of the proton given as 2.798444 ± 0.0000011 in units of $\frac{e\hbar}{2M_p}$.
3. Set up the oscillator so the frequency is somewhere about 17 MHz. Compute the required B field for the frequency you have chosen.
4. Set the magnet for this B field using the Hall Effect gauss meter. The required current should be about 4 A.
5. Set the modulation field to mid range and measure this field with the Hall Effect meter set for AC measurements.
6. Take the “standard sample” and find the resonance. Study the resonance using both sinusoidal and linear sweeps. Note the differences.
7. Estimate the relative width (full width at half maximum height) of the resonance by changing the frequency slightly until the resonance has moved by its own width.
8. Verify that you have the probe in the optimum location by moving the probe slightly away from the center of field. Notice what happens to the resonance frequency and width. Why?
9. Look at the resonance signals of the other samples and pick the one which gives the strongest signal. Determine the resonance conditions as precisely as possible by reducing the modulation field. Consider this as a precision measurement of the B field. The accuracy should far exceed that possible using the Hall Effect meter but the results should, of course, be consistent.
10. Measure the resonance signal as a function of frequency over the frequency range of the oscillator. Five different frequencies should be sufficient. The relation between f and B should be linear. The f -current relation is not necessarily linear because of magnetic saturation in the iron of the magnet poles.

11. Choose a frequency that gives a high quality resonance signal and study the resonance signal of different samples.
12. For a least one sample make a careful determination of the line width and use this to compute the relaxation time T_2 . What should be the effect of different concentrations of the added salts?

Method for Locating an NMR Signal

Initial Settings

a. Oscilloscope

Connect the x and y inputs to the appropriate connections on the rack mounted chassis which contains the sweep controls and scope connections. This chassis also contains all the power supplies for the oscillator chassis which holds the probe coils. Set the scope up for x-y mode operation.

b. NMR Chassis

- 1) Turn on the power of the NMR chassis and Counter.
- 2) Check that “RF” BNC is connected by a short cable to the counter input.
- 3) Set “modulation” to mid range(~ 2 volts peak to peak).
- 4) Set the “RF level ” control centered.

c. Magnet Supply

- 1) Set “coarse” and “fine” to zero.
- 2) Set “mode” to current.
- 3) Turn on the magnet cooling water (a small flow of about 1 cup/minute).
- 4) Now turn on the magnet power switch.

d. NMR Probe

- 1) Set the “RF level” so that the RF voltage is on and near the middle of the voltage range. Check the RF level directly using the scope.
- 2) Check that three cables from the oscillator chassis are connected. RF goes to the frequency counter, SWEEP goes to X scope input, and AF OUT goes to Y scope input.
- 3) The counter should now be counting the RF. You can now adjust the frequency using the large dial on the oscillator chassis.

e. NMR Probe Again

- 1) Insert the standard sample. (the one with a cork)
- 2) Adjust the probe until the sample is in the approximate center of the field region. You will later move the probe to find the region which gives the largest signal, but as yet you do not know the location for maximum signal.

Operation

- a. Set the scope for X-Y operation. You should see a horizontal trace and a few mV of noise.
- b. Set the magnetic field to your calculated value by slowly raising the current while monitoring the magnetic field with the Hall probe. (about 4 Amps). Then if the signal does not immediately come into view, scan the magnetic field very slowly with the course dial. A resonance will show as two positive-going peaks of about 40 mV. (Why two?) Once the signal is seen, the RF level should be adjusted to optimize the signal.
- c. Now while watching the scope, move the probe slightly in the magnetic field in all directions to find the best resonance
 - 1) The magnetic field at the sample may change slightly while you do this, adjust the “frequency” control if necessary.
 - 2) Again check the frequency, adjust the probe frequency dial if necessary.

- d. Now adjust the RF level again to obtain the highest quality resonance signal.

Take care - the RF level will change the frequency slightly - so don't change it much in each try and adjust the probe dial to restore the frequency.